

HYDRAULIC KOOI-REACHFORKS®

Dual pallet handling

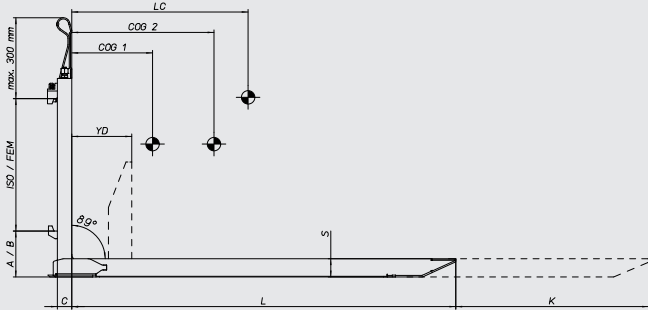

Dual-pallet handling and extension forks:

Mainly on counterbalance and reachtrucks for variable lengths and dual pallet handling.

- Damages of oversized forks will be history!
- Improving handling speed by lifting two pallets.

Extension range - mainly on counterbalance and reachtrucks for variable lengths and dual-pallet handling

Model	Capacity on LC 600 mm (kg)	Section D1/D2xS (mm)	L / K (mm)	C (mm)	CoG1 (mm)	CoG2 (mm)	Weight per pair (kg)	ISO/FEM
REE2 17 0800/0400	1700	128/128x40	0800/0400	40	215	240	90	2A
REE2 17 1000/0200			1000/0200		290	310	105	
REE2 17 1200/0800			1200/0800		375	495	116	
REE2 24 0800/0400	2400	131/131x44	0800/0400	45	220	275	104	2A
REE2 24 1000/0200			1000/0200		300	325	121	
REE2 24 1200/0800			1200/0800		385	510	135	
RGE2 20 0800/0400	2000	131/131x57	0800/0400	45	233	293	113	2A
RGE2 20 1000/0200			1000/0200		316	340	133	
RGE2 20 1200/0800			1200/0800		397	520	145	
RGE2 30 0800/0400	3000	131/131x57	0800/0400	45	220	275	122	3A
RGE2 30 1000/0200			1000/0200		302	327	144	
RGE2 30 1200/0800			1200/0800		382	515	158	

Remark:

- Extension Range forks need a minimum overlap of 400 mm (retracted length-stroke).
- Minimum operating pressure 160 bar, maximum 250 bar.
- Recommended maximum oil flow 25 l/min.
- Type RE delivered including separate flow divider and four hydraulic hoses. Type RG delivered including one hydraulic hose.
- For optimal speed and minimum loss of pressure the recommended minimum hose diameter is 8 mm.
- In cold-storage applications KOOI-REACHFORKS® can be used down to -30 degrees Celcius, contact your dealer.
- The lift truck manufacturer must determine the combined KOOI-REACHFORKS® and lift truck capacity.

HYDRAULIC KOOI-REACHFORKS®

Dual pallet handling

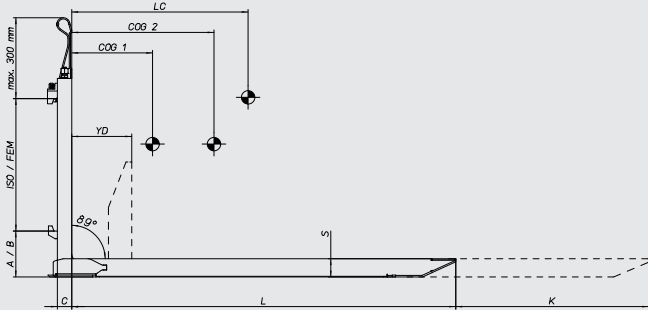

Dual-pallet handling and extension forks:

Mainly on counterbalance and reachtrucks for variable lengths and dual pallet handling.

- Damages of oversized forks will be history!
- Improving handling speed by lifting two pallets.

Extension range - mainly on counterbalance and reachtrucks for variable lengths and dual-pallet handling

Model	Capacity on LC 24" (Lbs)	Section D1/D2xS (In)	L / K (In)	C (In)	CoG1 (In)	CoG2 (In)	Weight per pair (Lbs)	ISO/FEM
REE2 17 0800/0400	3.750	5.0/5.0x1.6	31.5/15.7	1.6	8.5	9.4	200	2A
REE2 17 1000/0200			39.4/7.9		11.4	12.2	230	
REE2 17 1200/0800			47.2/31.5		14.7	19.5	255	
REE2 24 0800/0400	5.300	5.2/5.2x1.7	31.5/15.7	1.8	8.7	10.8	229	2A
REE2 24 1000/0200			39.4/7.9		11.8	12.8	266	
REE2 24 1200/0800			47.2/31.5		15.2	20.1	297	
RGE2 20 0800/0400	4.400	5.2/5.2x2.2	31.5/15.7	1.8	9.2	11.5	325	2A
RGE2 20 1000/0200			39.4/7.9		12.4	13.4	343	
RGE2 20 1200/0800			47.2/31.5		15.6	20.5	375	
RGE2 30 0800/0400	6.600	5.2/5.2x2.2	31.5/15.7	1.8	220	10.8	340	3A
RGE2 30 1000/0200			39.4/7.9		302	12.9	360	
RGE2 30 1200/0800			47.2/31.5		382	20.3	395	

Remark:

- Extension Range forks need a minimum overlap of 15.7 Inch (retracted length-stroke).
- Minimum operating pressure 2320 Psi, maximum 3625 Psi.
- Recommended maximum oil flow 5.5 gal/min.
- Type RE delivered including separate flow divider and four hydraulic hoses. Type RE delivered including one hydraulic hose.
- For optimal speed and minimum loss of pressure the recommended minimum hose diameter is 0.31 Inch.
- In cold-storage applications KOOI-REACHFORKS® can be used down to -13 F°, contact your dealer.
- The lift truck manufacturer must determine the combined KOOI-REACHFORKS® and lift truck capacity.