

ROLLERFORKS®

Palletless handling of single stacked goods

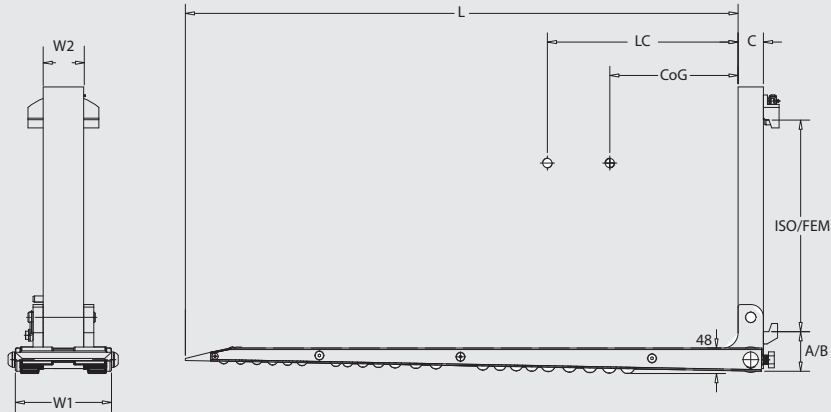

ROLLERFORKS®, no hydraulic required

Model	Capacity on LC 500 mm (kg)	L (mm)	W1 (mm)	W2 (mm)	C (mm)	CoG (mm)	Weight per pair (kg)	ISO/FEM
RFC 10-1100-D1	1000	1100	190	80	50	343	130	2A
RFC 10-1200-D1		1200				394	135	2A
RFC 15-1100-D1	1500	1100	160	80	50	378	115	2A
RFC 15-1200-D1		1200				325	123	2A
RFC 20-1100-D1	2000	1100	210	100	60	337	147	2A
RFC 20-1200-D1		1200				388	155	2A
RFC 24-1100-D1	2400	1100	210	100	60	332	151	2A
RFC 24-1200-D1		1200				383	160	2A
RFC 30-1100-D1	3000	1100	310	130	60	320	255	3A
RFC 30-1200-D1		1200				373	270	3A

RollerForks® for refrigerated containers

RFCC 10-1100-D1	1000	1100	250	80	50	380	130	2A
RFCC 10-1200-D1		1200				420	138	2A
RFCC 20-1100-D1	2000	1100	270	100	60	349	160	2A
RFCC 20-1200-D1		1200				385	171	2A
RFCC 24-1100-D1	2400	1100	270	100	60	349	164	2A
RFCC 24-1200-D1		1200				391	176	2A

Optional:

- Foldable palletstop to reduce the blade length. Retracted 50mm, extended 200mm.
- Tube welded on the fork back to reduce the length (when length is shorter than 1000mm).

ROLLERFORKS®

Palletless handling of single stacked goods

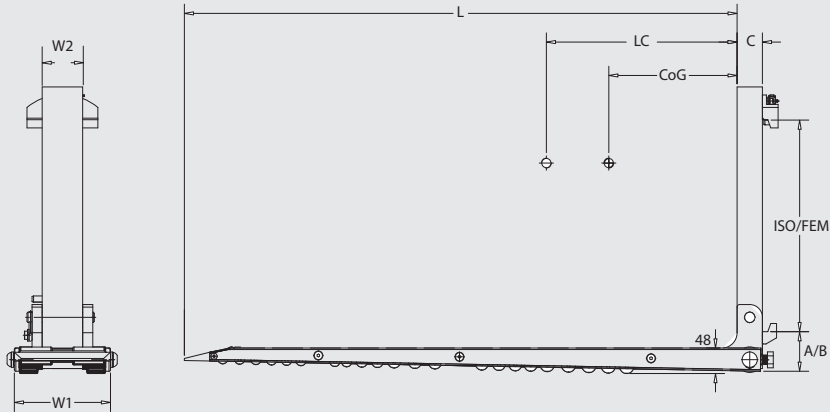

ROLLERFORKS®, no hydraulic required

Model	Capacity on LC 20" (Lbs)	L (In)	W1 (In)	W2 (In)	C (In)	CoG (In)	Weight per pair (Lbs)	ISO/FEM
RFC 10-1100-D1	2.200	43.3	7.4	3.1	1.9	13.5	286	2A
RFC 10-1200-D1		47.2				15.5	297	2A
RFC 15-1100-D1	3.300	43.3	6.2	3.1	1.9	14.8	253	2A
RFC 15-1200-D1		47.2				12.7	270	2A
RFC 20-1100-D1	4.400	43.3	8.2	3.9	2.3	13.2	323	2A
RFC 20-1200-D1		47.2				15.2	341	2A
RFC 24-1100-D1	5.280	43.3	8.2	3.9	2.3	13.0	332	2A
RFC 24-1200-D1		47.2				15.0	352	2A
RFC 30-1100-D1	6.600	43.3	12.2	5.1	2.3	12.5	561	3A
RFC 30-1200-D1		47.2				14.6	594	3A

RollerForks® for refrigerated containers

RFCC 10-1100-D1	2.200	43.3	9.8	3.1	1.9	14.9	286	2A
RFCC 10-1200-D1		47.2				16.5	303	2A
RFCC 20-1100-D1	4.400	43.3	10.6	3.9	2.3	13.7	352	2A
RFCC 20-1200-D1		47.2				15.1	376	2A
RFCC 24-1100-D1	5.280	43.3	10.6	3.9	2.3	13.7	360	2A
RFCC 24-1200-D1		47.2				15.3	387	2A

Optional:

- Foldable palletstop to reduce the blade length. Retracted 2 Inch, extended 7.9 Inch.
- Tube welded on the fork back to reduce the length (when length is shorter than 39.4 Inch).