

Mast Height Extension

This unique Mast Height Extension system is designed to provide additional lift height to a wide range of forklift trucks. This is especially useful if the existing mast does not comply with the requested height. The extra lift height may also allow for increased storage as more pallets can be stored at higher levels without changing the mast, (upright), on the forklift.

FEATURES

- Excellent visibility.
- Minimum lost load thickness.
- Existing lift truck forks can be used.
- Lift truck forks can be moved sideways.
- One hydraulic function.

OPTION

- Quick change mounting hooks.



Increase maximum height

The Mast Height Extension is designed to increase the lift truck height of an existing lift truck mast. By adding the Mast Height Extension to a lift truck you can increase the maximum height of your racking without the need to change the mast or buy a new lift truck. Similarly the Mast Height Extension can be used to improve under-door clearance whilst maintaining greatest possible lift height.

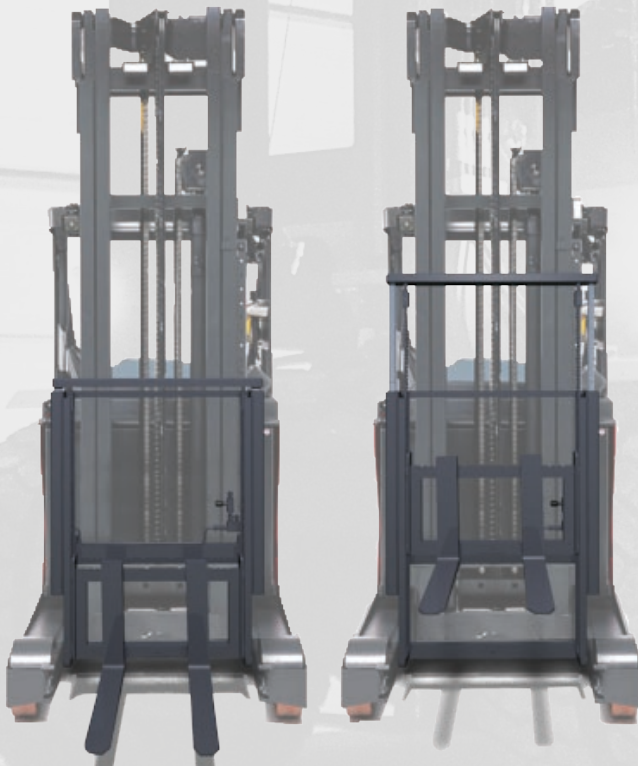

Heavy duty MHEH

MSE-FORKS is also able to provide you with a heavy duty Mast Height Extension (MHEH) with a capacity of 2000 kg., as well as 3000 kg., units with standard lift heights up to 1000 mm! The heavy duty units offer a clean, compact design with a lost-load-thickness of just 50 mm. This means there is minimal influence on the residual capacity of the lift truck.

Mast Height Extension

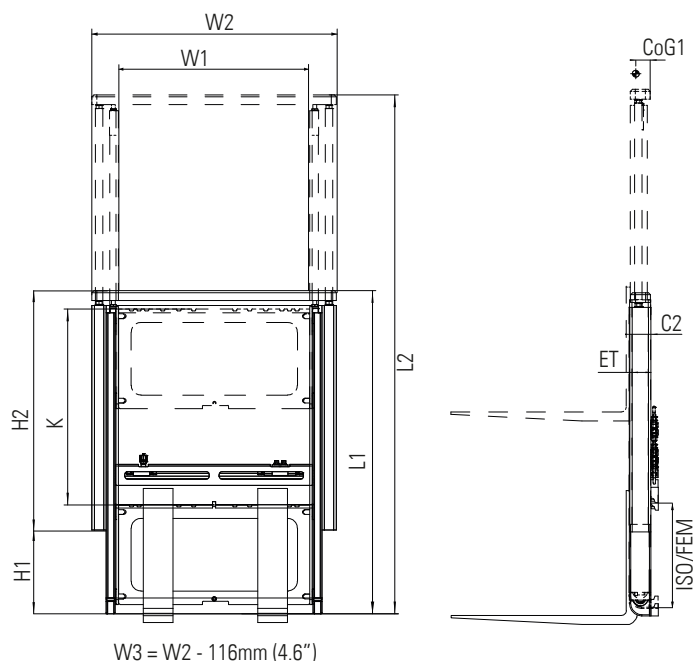

Mast Height Extension - one hydraulic function needed.

Model	Capacity on LC 600 mm (kg)	Stroke (K) (mm)	L1/L2 (mm)	H1 (mm)	H2 (mm)	W1 (mm)	W2 (mm)	ET (mm)	C2 (mm)	CoG1 (mm)	CoGv1 (mm)	CoGv2 (mm)	Weight (mm)
MHEH 20 0300 550	2000	300	0860/1160	343	517	550	764	50	85	30	415	540	129
MHEH 20 0500 550		500	1020/1520		677					31	495	680	147
MHEH 20 0700 550		700	1220/1920		877					32	585	830	167
MHEH 20 1000 550		1000	1520/2520		1177					33	720	1045	197
MHEH 20 0300 800	2000	300	0860/1160	343	517	800	1014	50	85	28	415	550	152
MHEH 20 0500 800		500	1020/1520		677					29	495	695	172
MHEH 20 0700 800		700	1220/1920		877					30	580	850	190
MHEH 20 1000 800		1000	1520/2520		1177					32	710	1065	220
MHEH 30 0300 800	3000	300	0930/1230	343	587	800	1014	57	85	25	465	615	182
MHEH 30 0500 800		500	1130/1630		787					28	540	775	202
MHEH 30 0700 800		700	1330/2030		987					29	620	926	223
MHEH 30 1000 800		1000	1630/2630		1287					30	745	1150	253
MHEH 30 0300 1000	3000	300	0930/1230	343	587	1000	1214	57	85	23	450	610	210
MHEH 30 0500 1000		500	1130/1630		787					25	530	770	230
MHEH 30 0700 1000		700	1330/2030		987					27	600	930	250
MHEH 30 1000 1000		1000	1630/2630		1287					28	715	1163	280

- Possible in combination with KOOI-REACHFORKS®.
- Minimum operating pressure 160 bar, maximum 250 bar.
- Optional: quick change mounting hooks.
- Capacities shown are nominal and apply to the attachment and not the lift truck.
- Other capacities and dimensions on request.
- Remark: When tilting mast carriage please contact MHS.