

## Stationary Pull Installation

The stand-alone Stationary "Push/Pull", SPI, provides a highly efficient and cost effective means of transferring unit loads from one load carrier to another. It's especially useful for keeping wooden pallets outside of cleanroom areas in order to comply with hygiene regulations.



This compact unit provides the beneficial features of a hydraulic push/pull attachment, (for slip-sheet handling), without the added expense of a dedicated forklift truck and an additional operator. This saves money. Loads are easily pulled from one pallet onto another. Delicate loads are safely transferred without the risks often associated with clamping or pushing. This reduces product damage and repackaging costs. It's also easy to use and does not require the skill levels necessary of forklift operators working with specialized attachments.

A small footprint, simple plug-n-play type design and an innovative laser-light safety curtain makes this unit ideal for placement within receiving areas. It offers an easy means of isolating unwanted pallets from other areas of the facility.

### Cost saving benefits:

- Reduce contamination risks.
- Avoid unnecessary costs (eliminate the need for an additional forklift).
- Reduce product damage (no pushing forces and no clamping forces on goods).
- Improve throughput rate (stationary placement for standardized process).
- Lower operational costs (low maintenance and low energy consumption).

### Innovative features:

- Simple construction.
- Heavy-duty design.
- Easy operation.
- No inversion of loads.
- Minimal floor space requirement.
- Remote controlled operation.
- L-shape Safety light curtain.
- Independent hydraulic system.
- Plug & play design.

**KOOI** SYSTEMS®

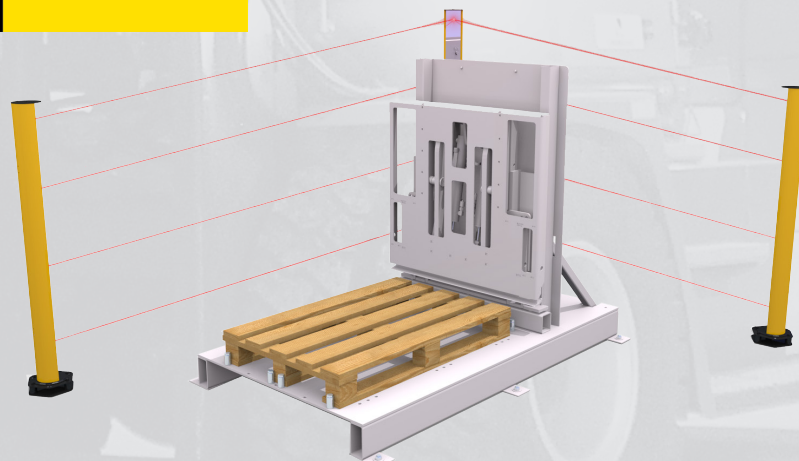

## Stationary Pull Installation

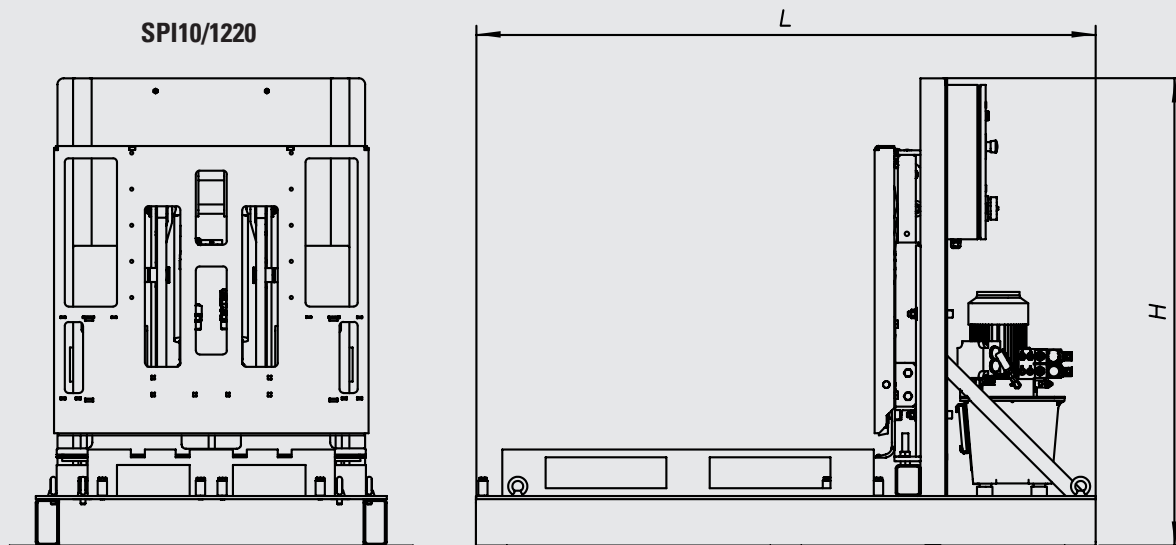

### METRIC

Model	Loading Capacity (kg)	L (mm)	H (mm)	Width (mm)	Power Supply	Weight (kg)	Safety Circuit
SPI10/1220	1000	2000	1515	1305	3ph/400V/16A/50Hz or 3ph/208V/16A/60Hz	790	CAT3/PLd

#### Standard

- Two sided safety light curtain

#### Optional

- Three sided safety fence
- Galvanized or stainless steel construction parts
- Warning buzzer and warning beacon light
- Oil level and temperature warning
- Other voltages, amperes and capacities on request